

N A B - 2 5 0

# HADES



The cutting edge  
**nantsune**

High speed automatic band saw



Processing  
Plant



Frozen

**Astonishing chucking residual meat thickness  
at a minimum of 15mm**

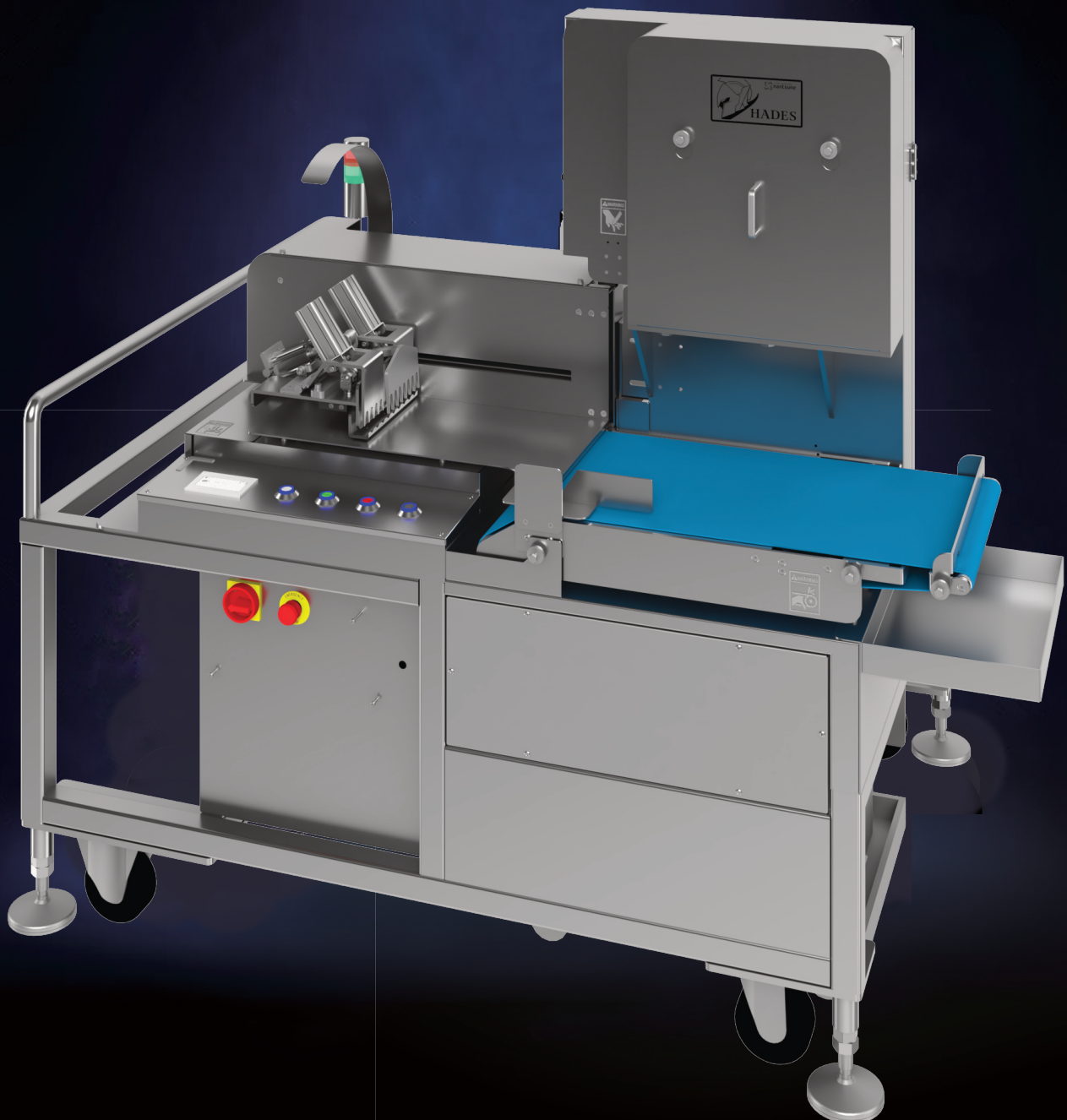

## Ideal for producing short ribs

- High-speed slicing of 80 slices per minute for thicknesses up to 15mm. We also paid particular attention to the beauty of the cross section of the slice.

## Astonishing yield with chucking residual meat of only 15mm

- Proprietary two-step chucking mechanism holds the meat firmly and makes adjustment depending on the remaining length of the material. When the meat is near the end of slicing, the counter plate pushes the remaining for a final slice to minimize the thickness of residual meat down to 15mm.
- The length of raw meat is automatically measured, and the most efficient initial cutting position based on the thickness setting is automatically calculated to minimize the amount of residual meat and improve yield.

## Smooth receiving process by enabling shingles

- Unique conveyor control enables shingles discharge. Slicing and receiving tasks that used to require two people, can now be handled by one person.

## Automatically adjusts the tension of the blade and also has a load detection function.

- The tension of the blade is automatically controlled by an air cylinder. The load detection function changes to the optimum operating speed depending on the deterioration of the blade and the condition of the raw material.

## Designed with thorough safety in mind

- Requires pushing switches by both hands to start the machine
- In case of no operation for a certain period of time, the blade stops automatically
- When stopped, the blade is hidden inside the cover
- Safety design that automatically stops operation if the blade comes off and prevents popping out even in the event of an accident
- Locks the door when the blade is rotating or when coasting after stopping



Proprietary two-step  
chucking mechanism



Counter plate pushes the  
remaining meat for a final  
slice to minimize the  
thickness of residual meat  
down to 15mm



Unique conveyor control  
enables shingles  
discharge



Automatically adjusts the  
tension of the blade and  
also has a load detection  
function



Safety-conscious two-  
hand push switch

## ■ Appearance Dimensional Drawing

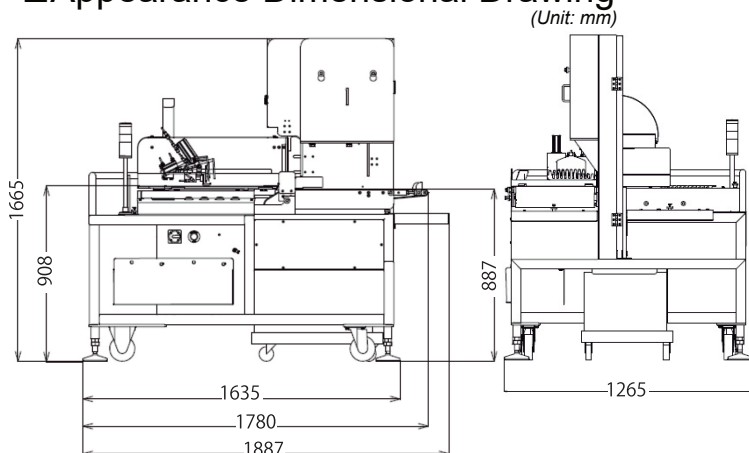

## ■ Specifications

<b>Machine Dimensions:</b>	W1,887 x D1,265 x H1,665mm
<b>Machine Weight:</b>	Around 600kg
<b>Motor Capacity:</b>	For round blade: 1.5kW For feeder: 0.1kW For tank: 0.75kW For conveyor: 0.09kW
<b>Power Consumption:</b>	240W (50Hz/60Hz No load)
<b>Slicing Performance:</b>	80 pieces/min (5.0~15.0mm) 70 pieces/min (15.1~25.0mm) 60 pieces/min (25.1~35.0mm) 50 pieces/min (35.1~60.0mm)
<b>Sliceable Dimensions:</b>	W250 x L300 x H100mm
<b>Max. Loading Weight:</b>	10kg
<b>Bandsaw Size:</b>	W16 x L2747mm
<b>Applicable Temperature:</b>	-20°C~-25°C <small>*Varies slightly depending on the thickness, texture and shape of the meat</small>
<b>Air Supply:</b>	0.5MPa 19.8L/min tube outer diameter 10mm

\*The specifications are subject to change without notice for product improvement.

Webpage

<https://www.nantsune.co.jp/en/>



Contact Us

<https://www.nantsune.co.jp/en/contacts/>

